

WARD 8 SHORT TERM FAMILY HOUSING

4225 6TH STREET, S.E.  WASHINGTON, DC 20032

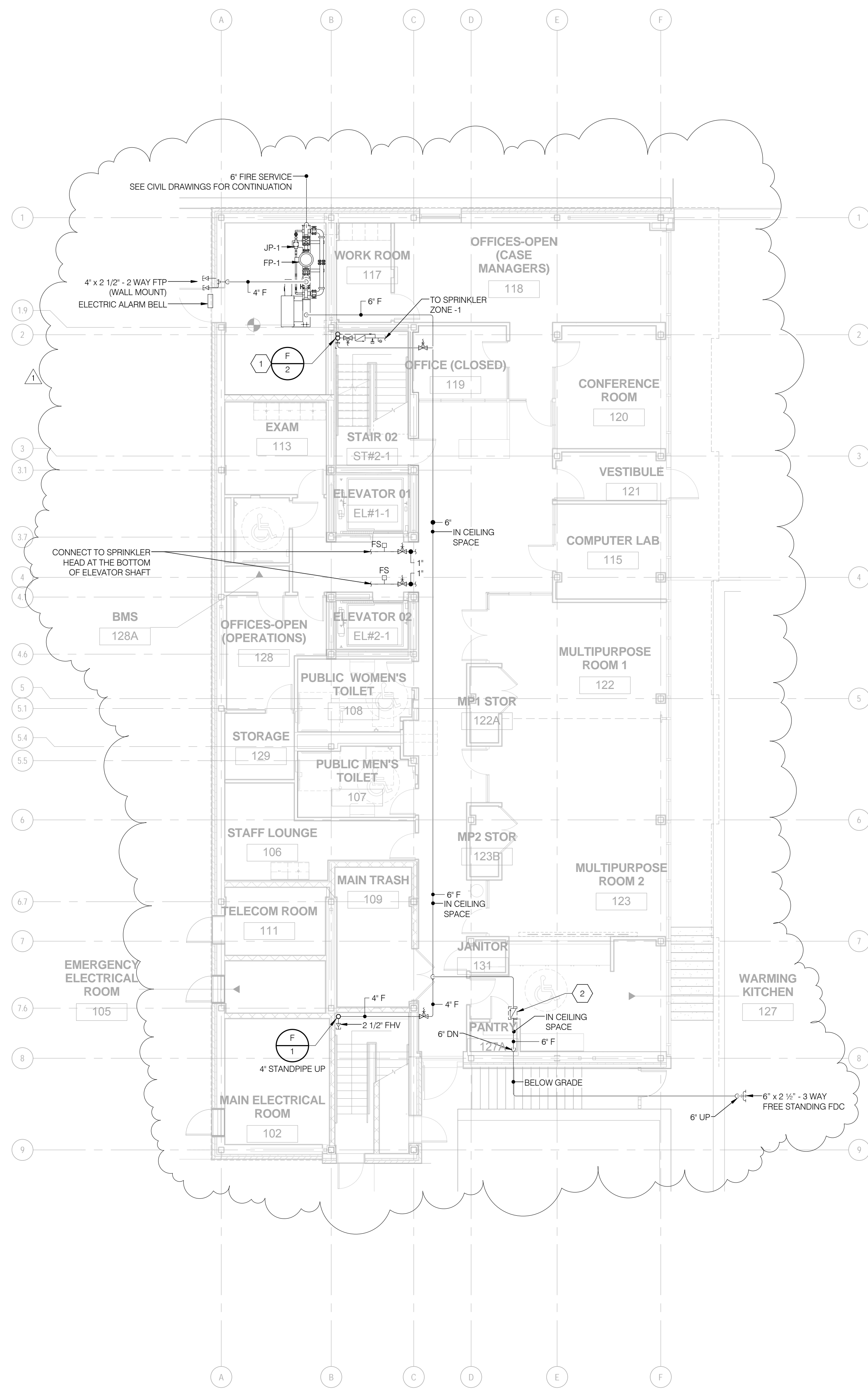

1 FIRE PROTECTION 1ST FLOOR PLAN
1/8" = 1'-0"

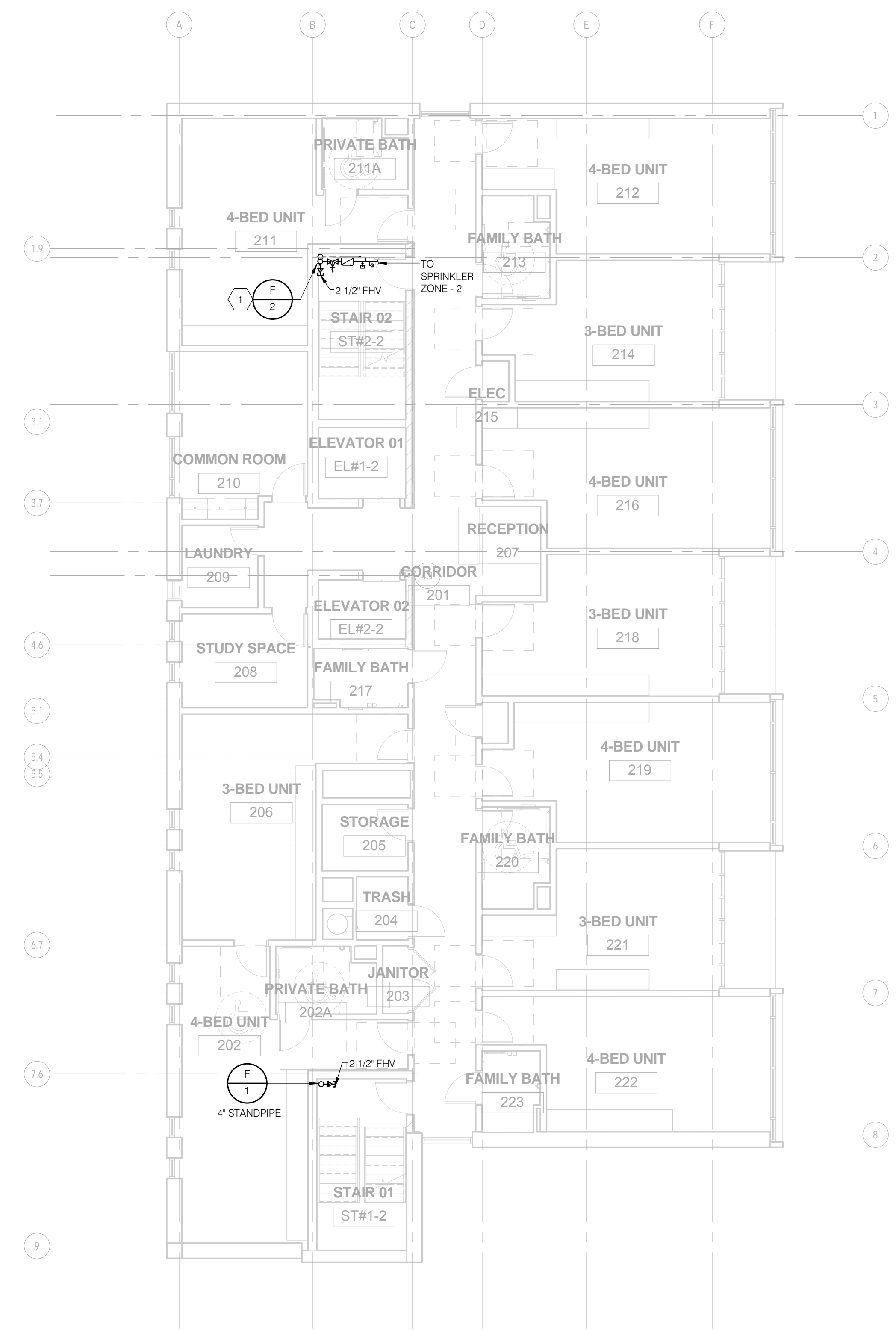

2 FIRE PROTECTION 2ND FLOOR PLAN
1/8" = 1'-0"

- SHEET NOTES
- 6" FIRE STANDPIPE SYSTEM WITH 2 1/2" FHV WITH CAP AND CHAIN. 2" SPRINKLER DRAIN RISER.
 - CHECK VALVE WITH AUTO-BALL DRIP. PROVIDE ACCESS PANEL TO ACCESS THE VALVE.



SETTY
3040 WILLIAMS DRIVE, SUITE 600
FAIRFAX, VA 22031
P: 703-691-2115
M/E/P/PP DESIGN/ENGINEERING • PROJECT MANAGEMENT
ENERGY MANAGEMENT SERVICES • DESIGN-BUILD SERVICES
CONSTRUCTION MANAGEMENT • COMMISSIONING
DISTRICT OF COLUMBIA • MARYLAND
NEW YORK • VIRGINIA
WWW.SETTY.COM
PROJECT NUMBER: SAIP16536.00

	22DEC 2017	VE / PERMIT RESUBMISSION		
	03NOV 2017	VE REVISIONS		
	13APR 2017	FINAL CONSTRUCTION DOCUMENTS		
DESIGNED	NS	13JAN 2017	PERMIT SUBMISSION REVISIONS	
DRAWN	NS	30NOV 2016	PERMIT SUBMISSION	
CHECKED	JW	REVISION	DATE	DESCRIPTION
CERTIFICATION	FIRST AND SECOND FLOOR FIRE PROTECTION PLAN			
	WARD 8 SHORT TERM FAMILY HOUSING 4225 6TH STREET, S.E. WASHINGTON DC, 20032			DRAWING NO. F1.1
	SORG ARCHITECTS 918 U ST, NW, WASHINGTON DC 20001 T: 202.393.6445 F: 202.393.6497			PROJECT NO. 55-161-6-00
REGISTRATION NO.	GOVERNMENT OF THE DISTRICT OF COLUMBIA			BLDG. NO.
DATE	DEPARTMENT OF GENERAL SERVICES			DATE:
				SHEET 3 OF 8

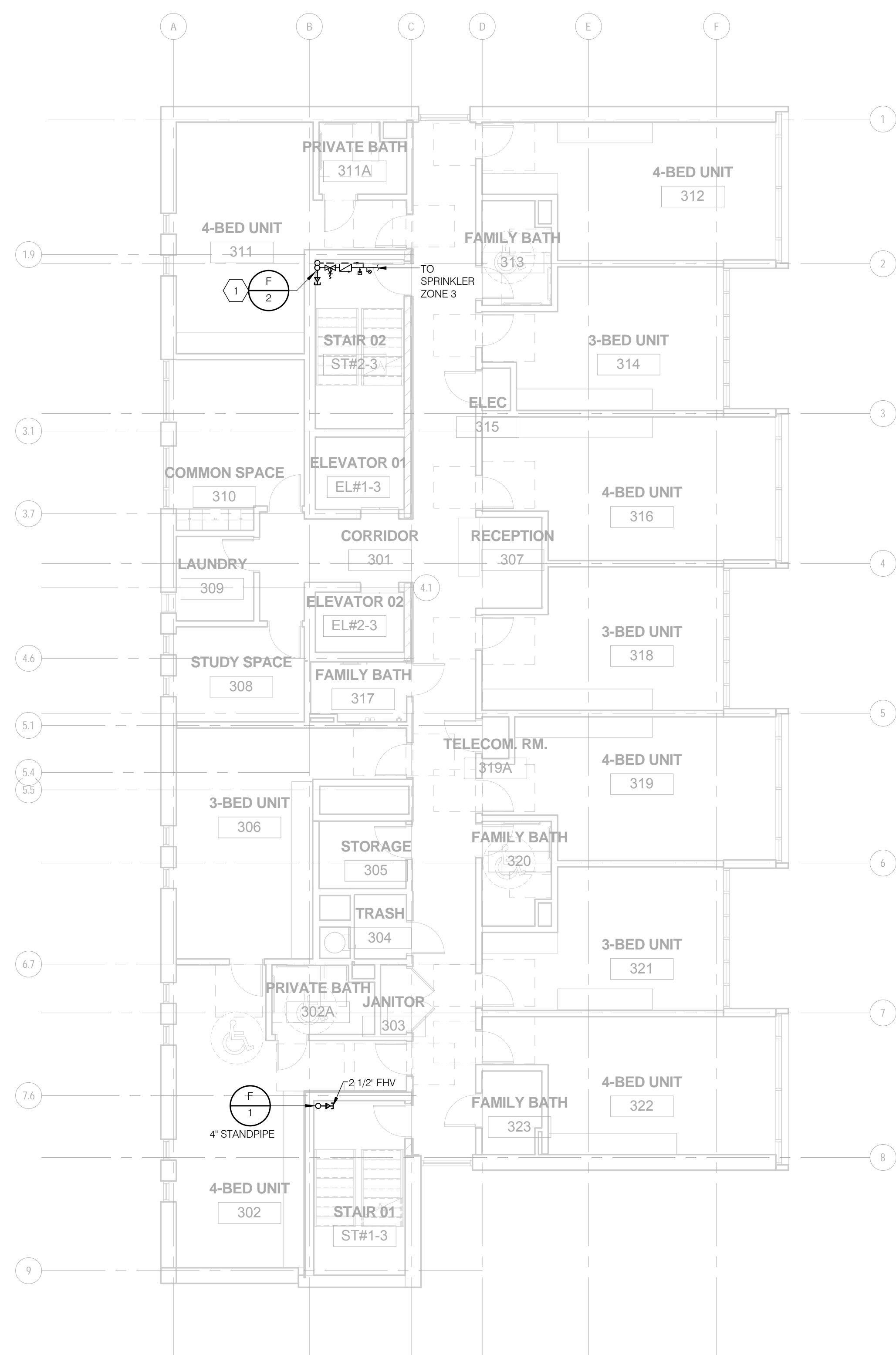

1 FIRE PROTECTION 3RD FLOOR PLAN
 F1.2 1/8" = 1'-0"

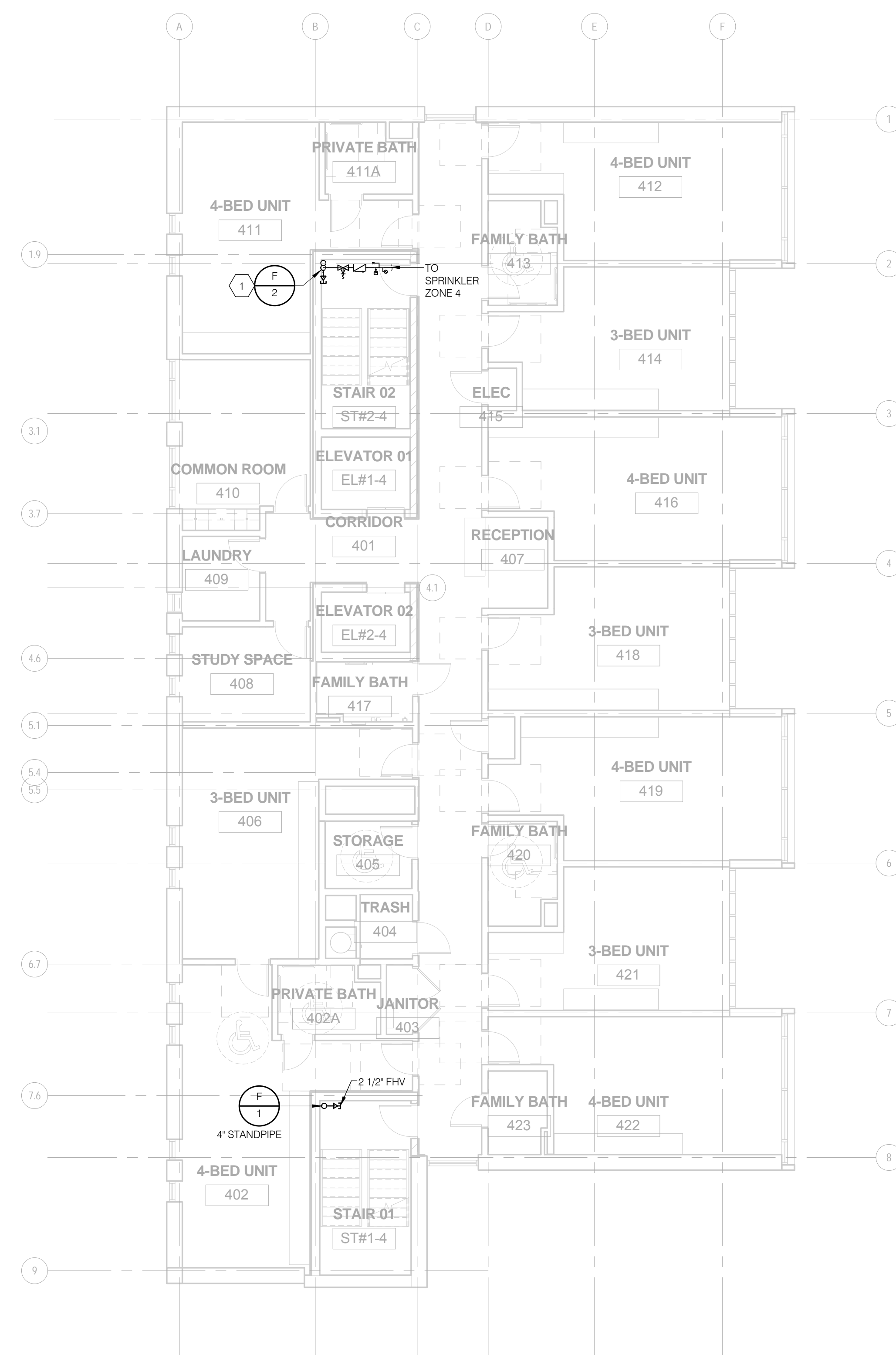

2 FIRE PROTECTION 4TH FLOOR PLAN
 F1.2 1/8" = 1'-0"

SHEET NOTES
 1. 6" FIRE STANDPIPE SYSTEM WITH 2 1/2" FHV WITH CAP AND CHAIN. 2" SPRINKLER DRAIN RISER.

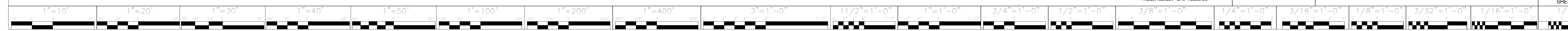

SETTY
 3040 WILLIAMS DRIVE, SUITE 600
 FAIRFAX, VA 22031
 P: 703-691-2115
 M/EP/PP DESIGN/ENGINEERING • PROJECT MANAGEMENT
 ENERGY MANAGEMENT SERVICES • DESIGN-BUILD SERVICES
 CONSTRUCTION MANAGEMENT • COMMISSIONING
 DISTRICT OF COLUMBIA • MARYLAND
 NEW YORK • VIRGINIA
 WWW.SETTY.COM
 PROJECT NUMBER: SAIP16536.00

	22DEC 2017	VE / PERMIT RESUBMISSION		
	03NOV 2017	VE REVISIONS		
	13APR 2017	FINAL CONSTRUCTION DOCUMENTS		
DESIGNED	NS	13JAN 2017	PERMIT SUBMISSION REVISIONS	
DRAWN	NS	30NOV 2016	PERMIT SUBMISSION	
CHECKED	JW	REVISION	DATE	DESCRIPTION
CERTIFICATION	THIRD AND FOURTH FLOOR FIRE PROTECTION PLAN			
	WARD 8 SHORT TERM FAMILY HOUSING 4225 6TH STREET, S.E. WASHINGTON DC, 20032			DRAWING NO. F1.2
	SORG ARCHITECTS 918 U ST., NW, WASHINGTON DC 20001 T: 202.393.6445 F: 202.393.6497			PROJECT NO. 55-161-6-00
REGISTRATION NO.	GOVERNMENT OF THE DISTRICT OF COLUMBIA			BLDG. NO.
DATE	DEPARTMENT OF GENERAL SERVICES			DATE:
				SHEET 4 OF 8

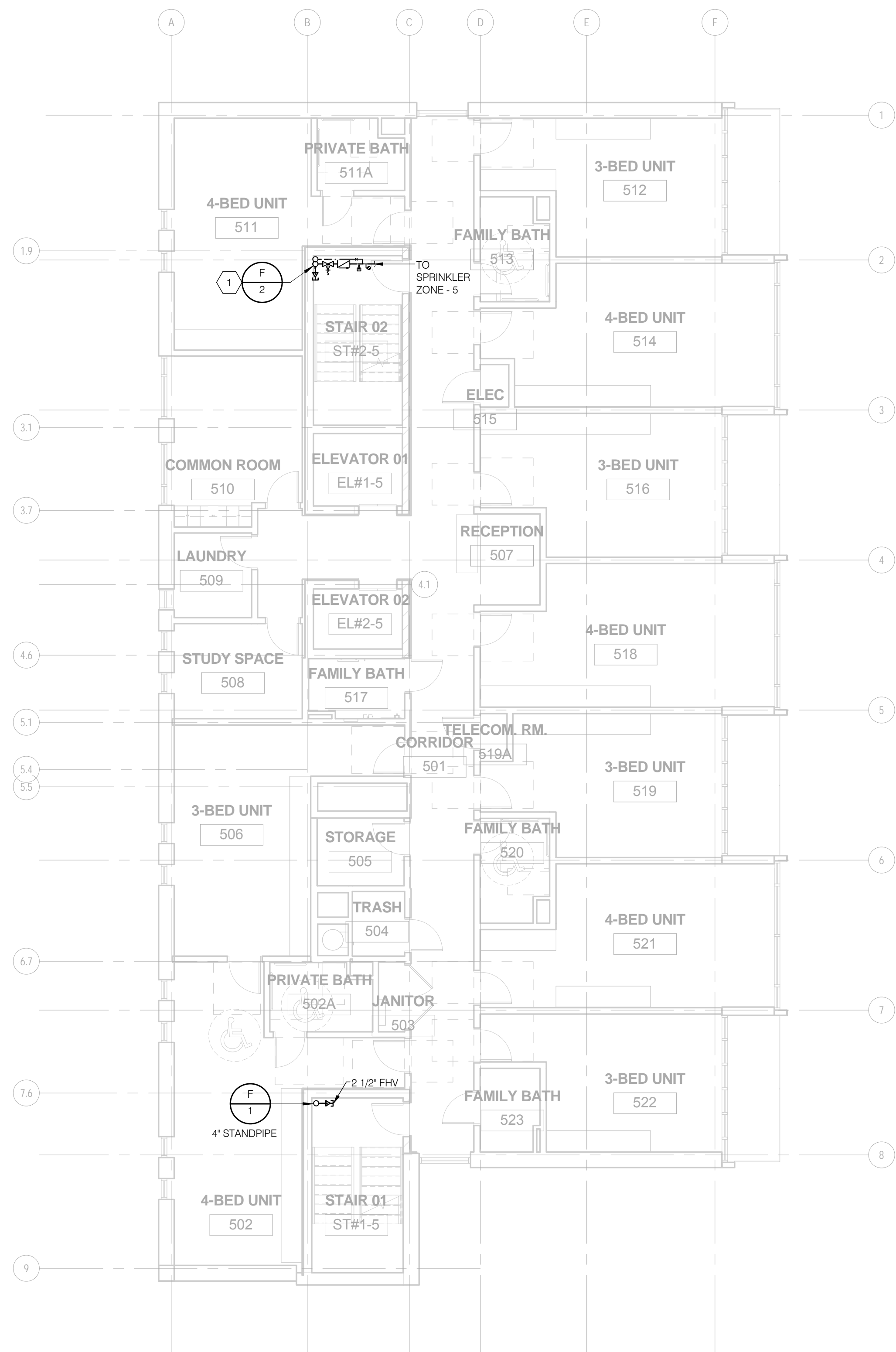

1 FIRE PROTECTION 5TH FLOOR PLAN
 1/8" = 1'-0"
 0 4 8 16

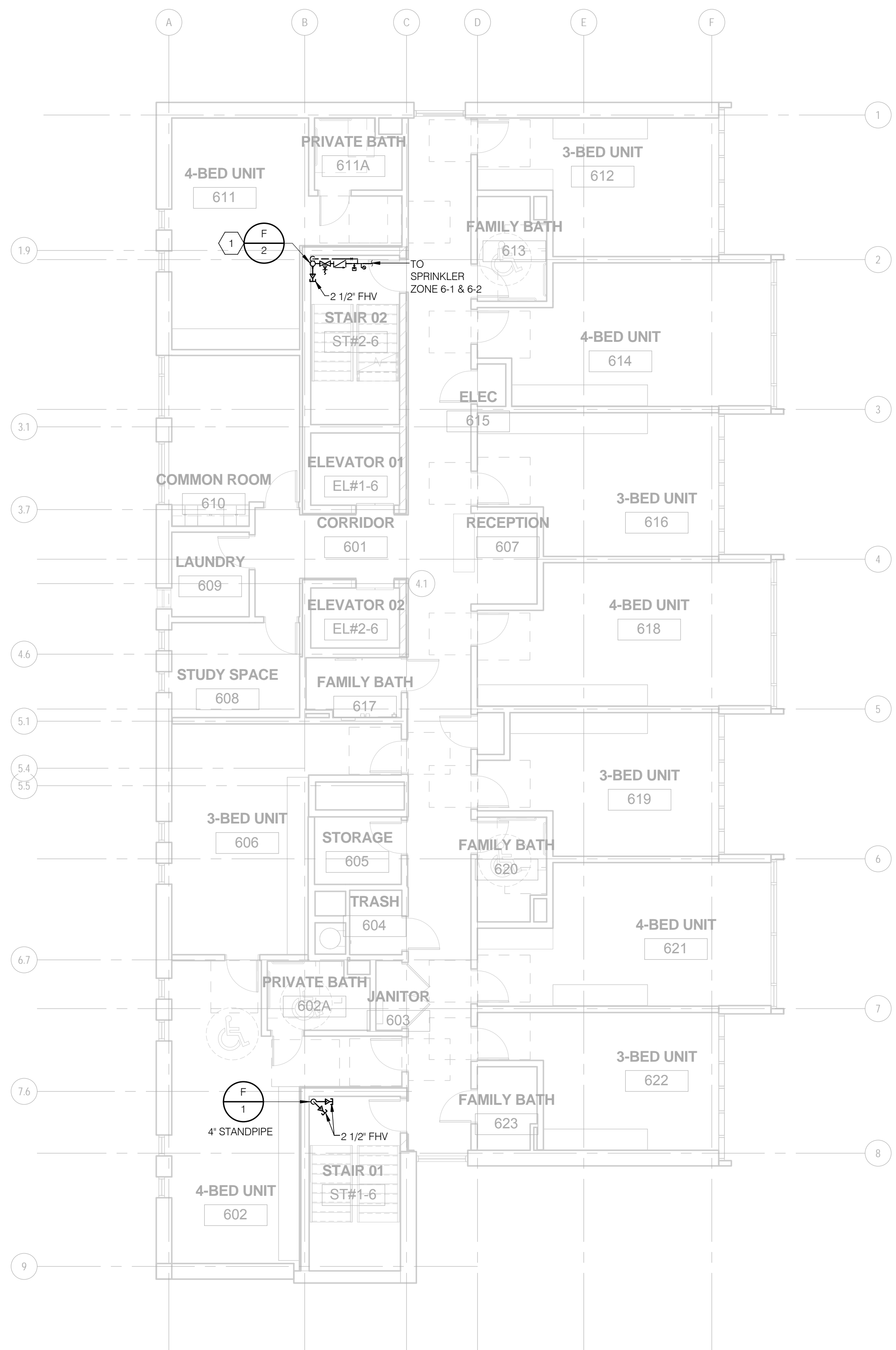

2 FIRE PROTECTION 6TH FLOOR PLAN
 1/8" = 1'-0"
 0 4 8 16

SHEET NOTES
 1. 6" FIRE STANDPIPE SYSTEM WITH 2 1/2" FHW WITH CAP AND CHAIN. 2" SPRINKLER DRAIN RISER.

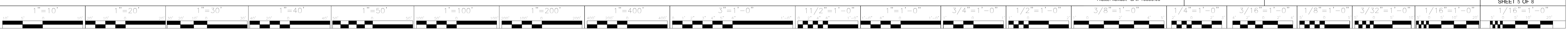

SETTY
 3040 WILLIAMS DRIVE, SUITE 600
 FAIRFAX, VA 22031
 P: 703-691-2115
 M/E/P/P DESIGN ENGINEERING • PROJECT MANAGEMENT
 ENERGY MANAGEMENT SERVICES • DESIGN-BUILD SERVICES
 CONSTRUCTION MANAGEMENT • COMMISSIONING
 DISTRICT OF COLUMBIA • MARYLAND
 NEW YORK • VIRGINIA
 WWW.SETTY.COM
 PROJECT NUMBER: SAIP16536.00

	22DEC 2017	VE / PERMIT RESUBMISSION		
	03NOV 2017	VE REVISIONS		
	13APR 2017	FINAL CONSTRUCTION DOCUMENTS		
DESIGNED	NS	13JAN 2017	PERMIT SUBMISSION REVISIONS	
DRAWN	NS	30NOV 2016	PERMIT SUBMISSION	
CHECKED	JW	REVISION	DATE	DESCRIPTION
CERTIFICATION FIFTH AND SIXTH FLOOR FIRE PROTECTION PLAN				
WARD 8 SHORT TERM FAMILY HOUSING 4225 6TH STREET, S.E. WASHINGTON DC, 20032			DRAWING NO.	
SORG ARCHITECTS 918 U ST., NW, WASHINGTON DC 20001 T: 202.393.6445 F: 202.393.6497			F1.3	
REGISTRATION NO.	GOVERNMENT OF THE DISTRICT OF COLUMBIA DEPARTMENT OF GENERAL SERVICES			PROJECT NO. 55-161-6-00
DATE				BLDG. NO.
				DATE:
				SHEET 5 OF 8

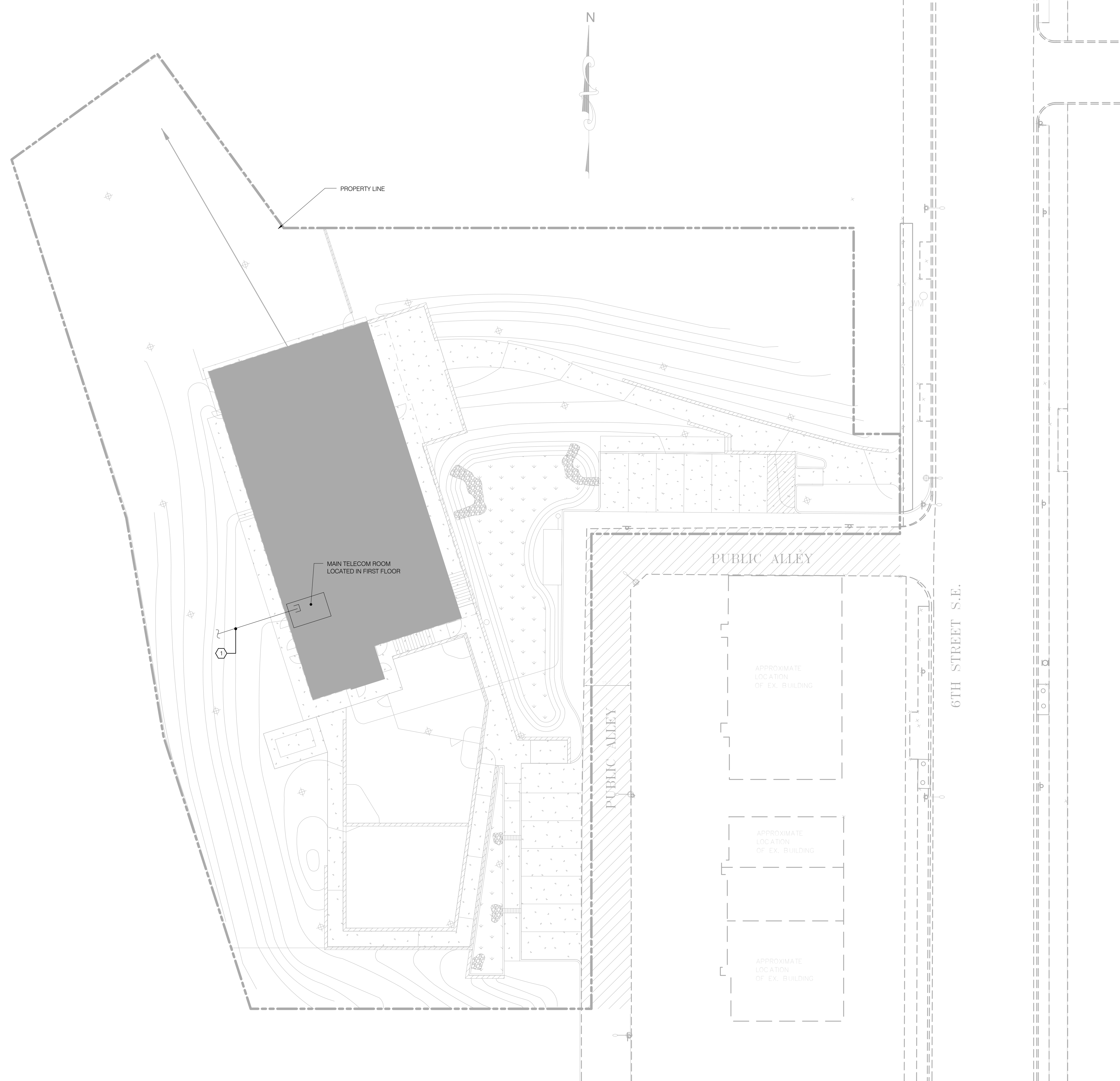

GENERAL NOTES

- SEE ARCHITECTURAL AND CIVIL SITE DRAWINGS FOR EXACT LOCATION OF ALL UTILITIES, UNDERGROUND MANHOLES, HANDHOLES, TREES, ETC PRIOR TO ANY ROUGH-IN WORK.
- PRIOR TO ANY INSTALLATION FIELD COORDINATE THE EXACT LOCATION OF UNDERGROUND CONDUITS WITH ALL OTHER UNDERGROUND UTILITIES AND THE SITE CONDITIONS.
- UTILIZE HAND DIGGING WHERE WORK IS REQUIRED IN THE VICINITY OF KNOWN UNDERGROUND UTILITIES. TAKE ALL NECESSARY PRE-CAUTIONS SO NO EXISTING UTILITIES GET ACCIDENTALLY DAMAGED.

SHEET KEY NOTES

- 4-4" TELECOM SERVICE ENTRANCE CONDUITS IN CONCRETE ENCASED DUCT BANK. EXTEND DUCT BANK 5' BEYOND PROPERTY LINE AND CAPPED FOR FINAL CONNECTION BY TELECOM SERVICE PROVIDER.

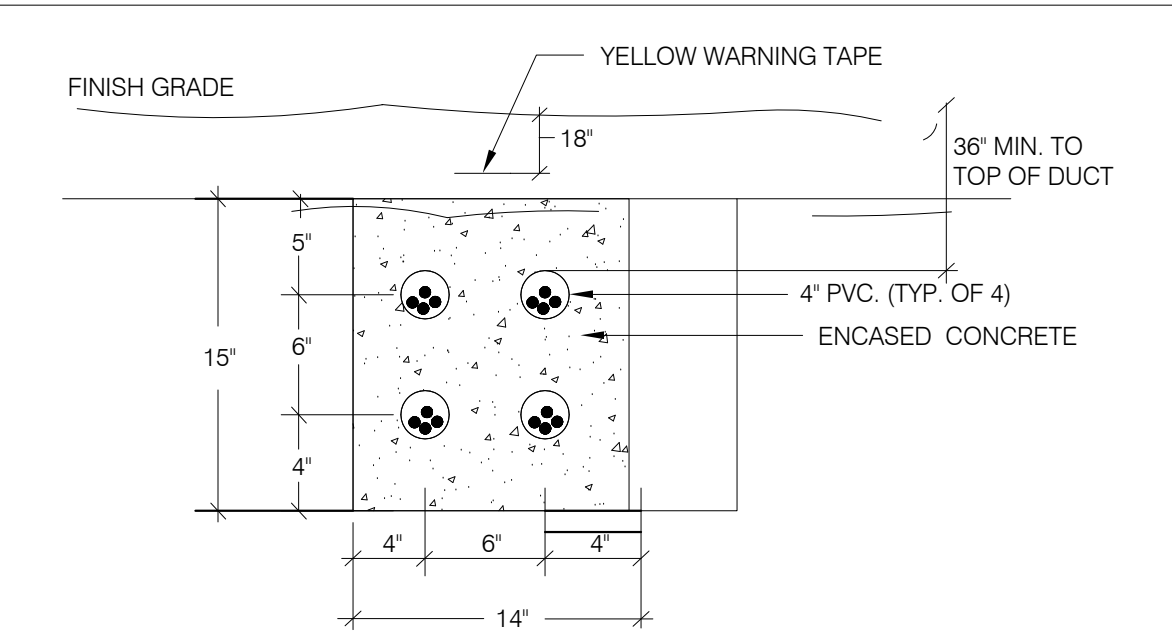

GENERAL NOTES

- PROVIDE GRAVEL MINIMUM 12" IN DEPTH BENEATH AND ALONG ROUTING OF THE DUCT BANK.
- ALL CONDUITS IN DUCTBANK TO BE SEALED WATERTIGHT.
- SLOPE DUCTBANKS TO MAINTAIN 36" MINIMUM OF COVER.

2
E0.4
4" - 4 WAY DUCT BANK A-A (2Hx2V)
SCALE: NOT TO SCALE

1
E0.4
TELECOM SITE PLAN
SCALE: 1/16" = 1'-0"

SETTY
3040 WILLIAMS DRIVE, SUITE 600
FAIRFAX, VA 22031
P: 703-691-2115
M/E/P/ DESIGN ENGINEERING • PROJECT MANAGEMENT
ENERGY MANAGEMENT SERVICES • DESIGN-BUILD SERVICES
CONSTRUCTION MANAGEMENT • COMMISSIONING
DISTRICT OF COLUMBIA • MARYLAND
NEW YORK • VIRGINIA
www.setty.com
PROJECT NUMBER: SAIP16536.00

	22 DEC 2017	VE / PERMIT RESUBMISSION		
	03 NOV 2017	VE REVISIONS		
	20 APR 2017	PERMIT SUBMISSION REVISIONS		
DESIGNED	KN	13 JAN 2017	PERMIT SUBMISSION REVISIONS	
DRAWN	RUP	30 NOV 2016	PERMIT SUBMISSION	
CHECKED	CDC	REVISION	DATE	DESCRIPTION
CERTIFICATION		TELECOM SITE PLAN		
WARD 8 SHORT TERM FAMILY HOUSING 4225 6TH STREET, S.E. WASHINGTON DC, 20032				DRAWING NO. E0.4
 SORG ARCHITECTS 918 U ST., N.W., WASHINGTON DC 20001 T: 202.393.6445 F: 202.393.6497				PROJECT NO. 55-161-6-00
GOVERNMENT OF THE DISTRICT OF COLUMBIA DEPARTMENT OF GENERAL SERVICES				BLDG. NO.
REGISTRATION NO. 900024 DATE: 8/5/2018				DATE:
				SHEET 4 OF 30

